

THE MODULAR GERMAN MICROSATELLITE TET-1 FOR TECHNOLOGY ON-ORBIT VERIFICATION

Stefan Föckersperger

Kayser-Threde GmbH, 81379 Munich, Germany, Stefan.Foekersperger@kayser-threde.com

Klaus Lattner

Kayser-Threde GmbH, 81379 Munich, Germany, Klaus.Lattner@kayser-threde.com

Clemens Kaiser

Kayser-Threde GmbH, 81379 Munich, Germany, Clemens.Kaiser@kayser-threde.com

Silke Eckert

Astro- und Feinwerktechnik GmbH, 12489 Berlin, Germany, s.eckert@astrofein.com

Wolfgang Bärwald

Astro- und Feinwerktechnik GmbH, 12489 Berlin, Germany, w.baerwald@astrofein.com

Swen Ritzmann

Astro- und Feinwerktechnik GmbH, 12489 Berlin, Germany, s.ritzmann@astrofein.com

Peter Mühlbauer

DLR-GSOC, 82234 Weßling, Germany, peter.muehlbauer@dlr.de

Michael Turk

DLR Space Agency, 53227 Bonn, Germany, michael.turk@dlr.de

Philipp Willemsen

DLR Space Agency, 53227 Bonn, Germany, philipp.willemsen@dlr.de

1. **ABSTRACT**

Due to the high safety standards in the space industry every new product must go through a verification process before qualifying for operation in a space system. Within the verification process the payload undergoes a series of tests which prove that it is in accordance with mission requirements in terms of function, reliability and safety. Important verification components are the qualification for use on the ground as well as the On-Orbit Verification (OOV), i.e. proof that the product is suitable for use under virtual space conditions (on-orbit). Here it is demonstrated that the product functions under conditions which cannot or can only be partially simulated on the ground.

The OOV-Program of the DLR serves to bridge the gap between the product tested and qualified on the ground and the utilization of the product in space. Due to regular and short-term availability of flight opportunities industry and research facilities can verify their latest products under space conditions and demonstrate their reliability and marketability. The

Technologie-Erprobungs-Träger TET (Technology Experiments Carrier) comprises the core elements of the OOV Program. A programmatic requirement of the OOV Program is that a satellite bus already verified in orbit be used in the first segment of the program. An analysis of suitable satellite busses showed that a realization of the TET satellite bus based on the BIRD satellite bus fulfilled the programmatic requirements best.

Kayser-Threde was selected by DLR as Prime Contractor for Phase B and C/D to perform the project together with its major subcontractors Astro- und Feinwerktechnik, Berlin for the platform development and DLR-GSOC for the ground segment development. TET is now designed to be a modular and flexible micro-satellite for any orbit between 450 and 850 km altitude and inclination between 53° and SSO. With an overall mass of 120 kg TET is able to accommodate experiments of up to 50 kg. A multipurpose payload supply system under Kayser-Threde responsibility provides the necessary interfaces to the experiments. The first TET mission is scheduled for mid of 2010. TET can be launched as piggy-back payload on any available launcher

worldwide to reduce launch cost and provide maximum flexibility. The TET-1 will be launched with SOYUZ/FREGAT. Finally, TET will provide all services required by the experimenters for a one year mission operation to perform a successful OOV-mission with its technology experiments leading to an efficient access to space for German industry and institutions.

This paper summarizes the results of the Phase B activities and of the Phase C/D activities up to now.

2. BACKGROUND

The goal of the OOV (On-Orbit-Verification)-Program is to qualify new technological solutions for their application in space projects. It focuses on the in-flight demonstration and verification of highly advanced technologies. The core element of the program is the micro-satellite TET (Technology Experiment Carrier) as a platform for the verification flight. With its high level of modularity it is able to be adapted to individual mission scenarios and flight opportunities.

2.1. The need for on-orbit verification

It is necessary to validate new, unproved techniques and technologies before using them in advanced missions. The OOV-Program fills the gap between a technology which has been qualified on the ground and its application in space. In order to support German industry and research institutes, the German Space Agency provides flight opportunities to qualify in-flight new technological solutions in all areas of spacecraft technology such as power generation and storage, propulsion, guidance, navigation and control.

The first part of the program is scheduled for the years 2005-2012. The overall budget of the program within this time span is about 34 M€. The program is conducted in cooperation with DLR Space Research (PD-W).

2.2. Flight opportunities

Flight opportunities for technology demonstration and verification should ideally be provided on a regular basis, independent, cost efficient and safe. A market survey of German industries' and institutes' technologies has shown that about 75 % of the experiments can be verified using a micro-satellite.

The OOV-Program is thus structured into two main parts with respect to the flight opportunities offered. The first comprises the micro-satellites TET with a planned flight every two years. For payloads which do not fit on TET, the DLR Space Agency cooperates with national and international partners in order to provide flight opportunities on other carriers.

3. MISSION OVERVIEW

The whole mission is designed based on the main mission requirements shown in Table.1.

Mission duration: 1 month LEOP incl. Satellite commissioning and 12 months mission operations
Type of Orbit: circular Orbit height: between 450 – 850 km Orbit inclination: 53° to sun-synchronous
Piggy-Back Launch
Reliability requirement: 0.9 (for platform and payload support system)
Ground stations: Weilheim for TT&C, Neustrelitz for payload data downlink
TET platform should be based on the BIRD satellite (maximum use of the BIRD heritage)
TET-1 Satellite mass: 120kg
Total Payload mass: 50kg

Table 1 TET main mission requirements

Derived from the above mentioned requirements and following a detailed mission analysis a mission scenario has been defined as shown in Figure 1. The TET-1 satellite is launched as piggy-back in a LEO orbit. After LEOP and commissioning the one year mission operation is controlled via the mission control centre in Oberpfaffenhofen. Payload data are stored in the payload data centre in Neustrelitz and can be retrieved from the experimenters via secured web access.

The essential conditions for operation of the P/L are:

- Electrical power supplied by the satellite bus to the single experiment,
- Thermal power consumption of the payload impacts the overall thermal system,
- Pointing mode of the satellite,
- Data take/rate of the experiment limited by the mass memory.

A careful mission planning for the experiments is necessary to be compatible with these conditions. The following principle operational scenarios are foreseen:

- Standard weekly mission scenario: the TET payload is operated according to a schedule that is repeated after one week (approx. 15 orbits with approx. 100 minutes data downlink every day).
- Mission scenario 12: 12 times per year continuous experiments lasting 4 days are performed.
- Mission scenario 2: 2 times per year experiments with direct space-ground link is foreseen lasting 2 days.

These operating scenarios are commanded from the ground station and controlled by the Payload Supply System which is detailed in chapter 4.3.2.

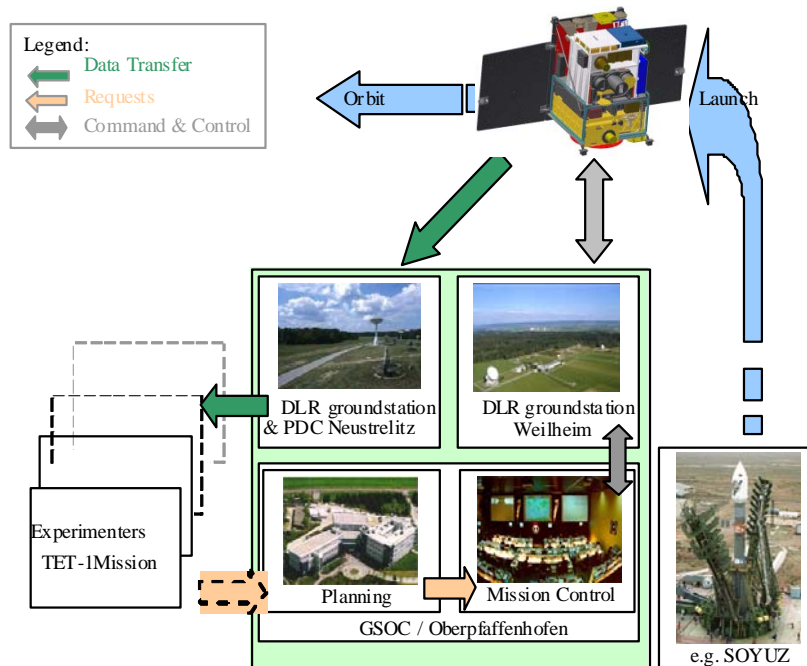

Figure 1: TET Mission Scenario

A flight opportunity with SOYUZ/FREGAT from Baikonur is selected to launch TET-1 into a dedicated orbit. TET-1 is intended to be launched together with a Russian weather satellite METEOR-2. Figure 2 shows a possible accommodation of TET-1 on SOYUZ/FREGAT. The final orbit of TET-1 is a sun-synchronous 550km altitude circular orbit. The main passenger of this launch will be separated into 820 km SSO. Due to its re-ignition capabilities, the FREGAT upper stage will perform dedicated orbital manoeuvres to inject TET-1 finally into the required 550 km SSO. During launch the satellite is inactive and after separation from the launcher the satellite is activated.

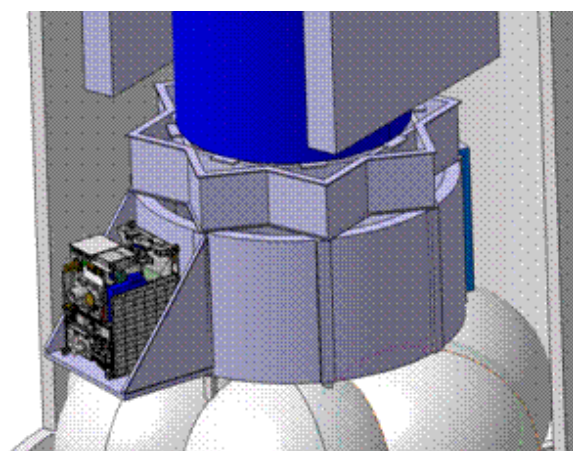

Figure 2: TET-1 Accommodation on launcher

The TET mission comprises the following mission phases.

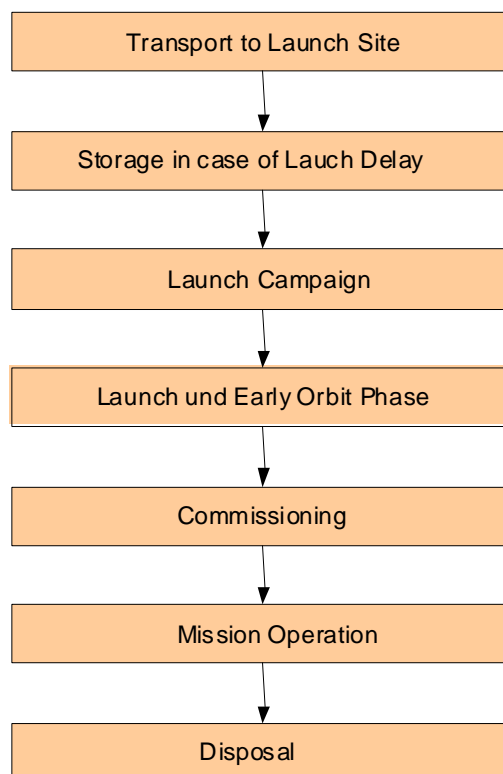

Figure 3: TET-1 mission phases

The main phases are described in more detail:

- LEOP: The Launch and Early Operations Phase will last a few days and has the goal to ensure satellite survival after separation from the launcher. Solar arrays will be deployed; satellite attitude will be stabilized to allow battery charging by the solar arrays and initial housekeeping data will be acquired from the LEOP ground station network. LEOP will end when the satellite is in a stable situation with respect to power, attitude and communications.
- Bus and Payload Supply System commissioning: Components which were not activated in LEOP will be activated. All subsystems of the satellite bus and the Payload Supply System will be thoroughly tested.
- Operational mission: The operational mission will last 12 months. Payload commissioning and payload operations will be performed in this phase.
- End of operations (disposal): In this phase the payloads will be switched off and passivation measures will be performed for the bus and the payloads.

The TET-1 mission is structured as shown in Figure 4 and consists of three main elements:

- Space segment,
- Ground segment, and
- Launch segment

Each of these elements has been designed in past project phases and the results for the main elements are shown in the forthcoming chapters.

One of the main tasks of the overall mission responsible is to manage the specific interfaces between the different elements as outlined in Figure 4. Being responsible for the complete payload with the complex accommodation of the 11 experiments into the fixed envelope, Kayser-Threde is interfacing also with each single experimenter directly being able to forward specific experimenter's needs directly to the affected mission element like bus or ground segment. Specifically TET is a typical example to interpret the prime role as the entity being responsible for the payload of a spacecraft which drives mainly the overall mission design finally leading to an efficient interface and project management.

During Phase B the TET system technical specification has been iterated to a status securing maximum flexibility w.r.t. final orbit, launcher and experimenter's interfaces. This will be realized by modularity on the one hand (like e.g. for the Payload Supply System) as well as flexibility of the overall spacecraft (e.g. thermal control, power generation) to cope with all potential orbital environments for a range of possible orbits leading to flexibility of launcher and finally flight opportunity selection.

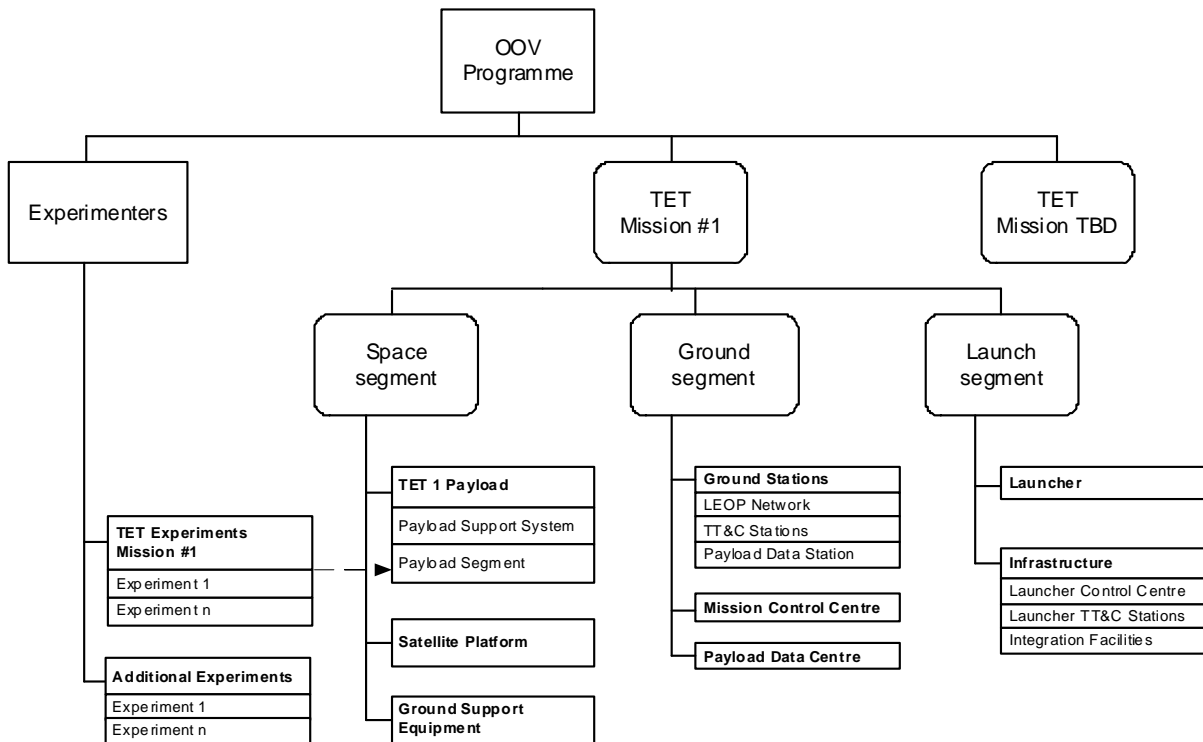

Figure 4: TET-1 Mission Elements

4. SPACE SEGMENT

4.1. Overview

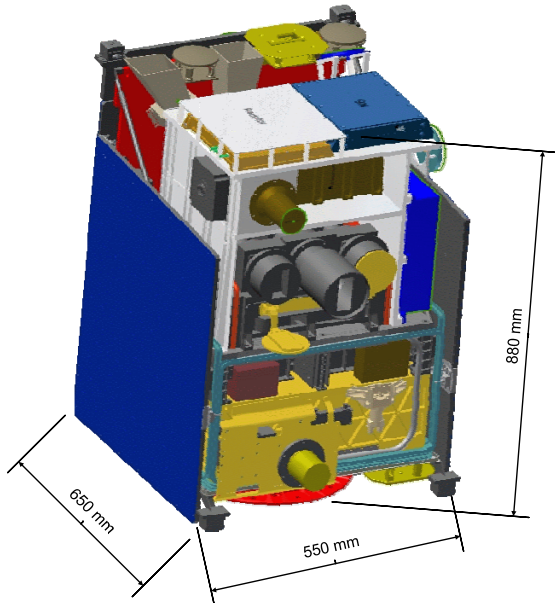

Figure 5: TET-1 Satellite (launch configuration)

The TET-1 Space Segment consists of the Satellite Bus and the Payload. At an overall mass of about 118kg the Payload including the Payload Supply System and necessary support structures contributes with about 50kg. Figure 5 below shows the Satellite Bus with integrated Payload in the launch configuration where the two solar panels on the left and right side are not deployed. The overall height of the Satellite is less than 880mm with a width of approximately 550mm and a depth of 650mm.

In the deployed configuration as shown in Figure 6 below, the Payload Segment can be seen more clearly. It is located on top of the Satellite Bus main structure with the Payload Base Plate as the mechanical and thermal interface.

To limit the development time and to reduce the project risk the TET-1 satellite bus is based on the heritage of the BIRD satellite bus [1]. The open satellite structure of the BIRD concept allows for a flexible payload accommodation which has been adapted for size and mass to fulfil the TET-1 needs.

Eleven experiments have been selected by DLR for this first TET mission. The experiments are developed by 11 different companies and institutions and comprise newest technology to be demonstrated for usage in space environment. The technical areas cover next generation solar arrays, navigation equipment, batteries, cameras, communication equipment, and satellite propulsion system and computer hardware.

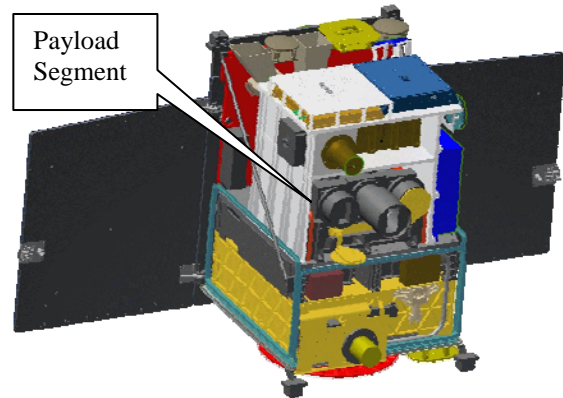

Figure 6: TET-1 Satellite (deployed configuration)

TET-1 Technical Data	
Dimensions:	880 mm x 550 mm x 650 mm (H x W x D) with about 90 liters of payload compartment
Mass:	Bus 70 kg Payload 50 kg
Number of experiments:	11
Stabilization:	3-axes
Pointing accuracy:	5 arcmin
Payload power consumption:	max 20W continuous
Uplink rate:	4 kbit/s
Downlink rate:	2.2 Mbit/s high rate
Orbit:	550 km, SSO
Launch:	Mid 2010
Mission duration:	one year

Table 2 TET-1 Technical Data

The Payload to Satellite Bus interface is realized and managed by the modular Payload Supply System, allowing to be customized with minimum effort to the experiment needs and thereby reducing the effort for recurring missions.

4.2. Satellite Bus

The TET satellite bus is a micro satellite bus based on the successfully employed micro satellite BIRD (Bi-spectral Infra-Red Detection).

On 22 October 2001 the micro satellite BIRD (Bi-spectral Infra-Red Detection) was launched successfully as secondary payload with the Indian rocket PSLV-C3 (Polar Satellite Launch Vehicle) into a circular sun-synchronous orbit of 572 km height. The satellite was designed, integrated and tested at

DLR Berlin-Adlershof. During the required life expectancy of 12 months all components worked correctly. For more than 80 months BIRD has been successfully sent data to earth.

In contrast to BIRD a higher payload total mass of 50 kg in a bigger dimension of 460 x 460 x 428 mm³ is available on TET-1 for the payloads that should be verified. The Payload Segment contains, besides the experiments, satellite bus components which need a dimension of approx. 100 x 275 x 220 mm³ for star cameras and 140 x 55 x 45 mm³ for magnetic field sensors (Figure 7).

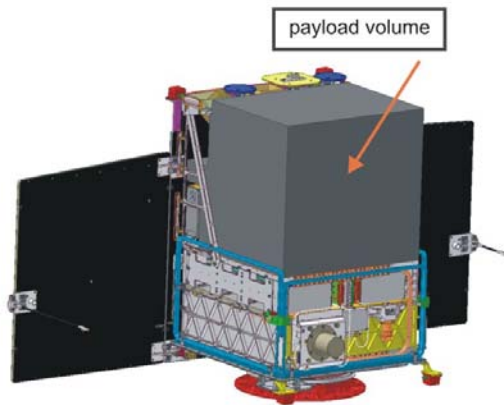

Figure 7: Available Payload Volume within TET-1

The satellite bus offers the possibility of fixing a payload panel above the central solar panel. Additional solar cells can also be installed on a special area on the central panel.

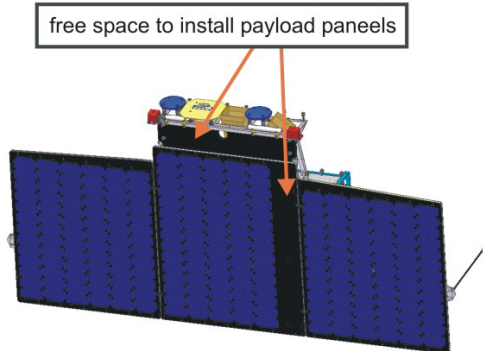

Figure 8: TET-1 Satellite Bus with Solar Cells and free space to install Payload Panels

Some other basic features of the TET satellite bus are the compact micro satellite structure with high mechanical stability and stiffness and a cubic shape in launch configuration with a dimension of 650 x 550 x 880 mm³ envelope. The TET satellite bus relies on a passive thermal control system with radiators, heat pipes, MLI, temperature sensors and contingency heaters.

The Power Subsystem consists of Power Control and Power Distribution Units, NiH₂ cell battery stacks including T-control and solar panels. The solar array consists of 3 panels; one fixed body mounted middle panel and 2 deployable side panels. The array is equipped with 246 solar cells (triple junction GaAs, efficiency 28%), with an electrical power of 220W (maximum power point). The capacity of the battery is 240 Ah, energy transfer is done by DET (Direct Energy Transfer).

The Spacecraft Bus Computer (SBC) controls all activities of the satellite bus. The SBC receives stores and processes the commands, gathers and evaluates the housekeeping data of all subsystems and controls the telemetry. Furthermore it is also the attitude control computer of TET. The SBC consists of four identical SBC boards and watchdog circuits for failure detection and recovery. The architecture of the redundant SBC boards (nodes) is totally symmetric, that means, each of the boards is able to execute all control tasks. One node (the worker) controls the satellite while a second node (supervisor) supervises the correct operation of the worker node. The two other node computers are spare components and are disconnected. If an anomaly of the worker node is detected by the supervisor node the supervisor substitutes the worker and takes over the control of the satellite.

The Attitude and Orbit Control System (AOCS) consists of two star sensors, two gyroscopes, two magnetometers, two sets of sun sensors, four reaction wheels and a magnetic coil system. The attitude control system provides a high degree of autonomy basing on a state-space representation of the attitude estimation, prediction and control, a real-time operation system embedding the attitude control software and a combination of the attitude control with an on-board navigation system (see Figure 9 and Figure 10).

One of the most complicated tests during the verification process of the TET satellite bus is the testing of the Attitude and Orbit Control System. Software-in-the-loop simulations and hardware-in-the loop simulations are well established test methods, but the best solution is real end-to-end test of the AOCS with a corresponding test facility. Based on the experiences with the BIRD AOCS test facility during the last years and the AOCS requirements, Astro- und Feinwerktechnik Adlershof GmbH has developed and built a new test facility for the end-to-end verification of the AOCS.

The communication takes place using S-Band with high bit rate (2,2 Mbit/s) and low bit rate. The transmitter and receiver channels are redundant and can be switched to all antennas.

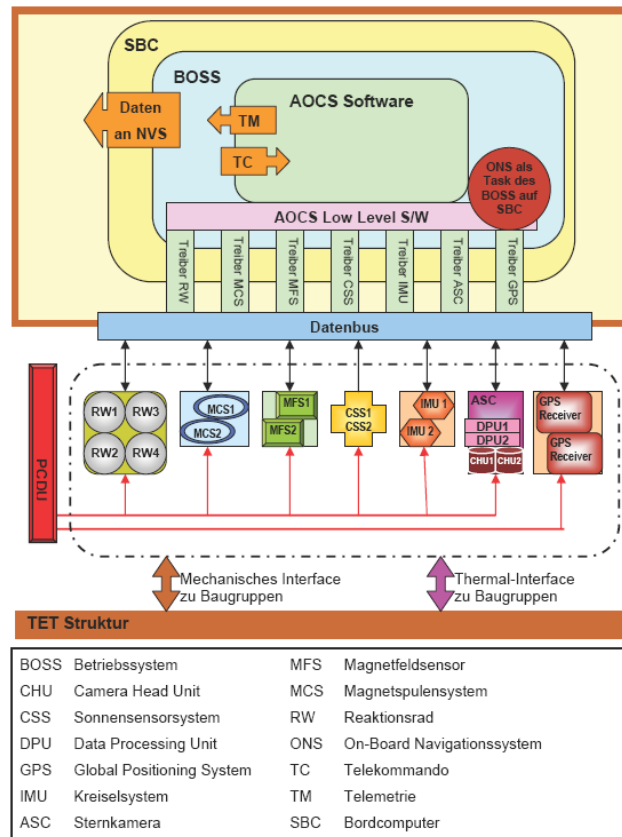

Figure 9: Scheme of the AOCS Interfaces

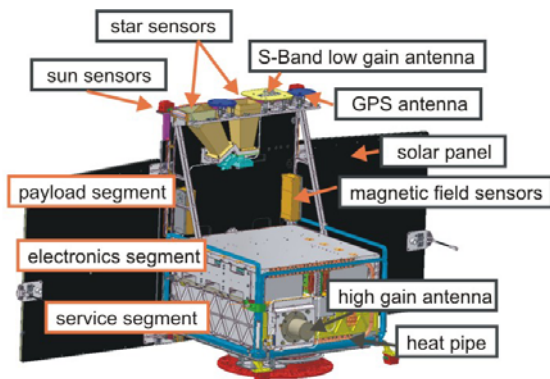

Figure 10: Components of the TET Satellite Bus

The TET Satellite bus consists of three compact segments. In the service segment a battery, reaction wheels, the power control and distribution unit and laser gyro are installed. The Satellite Board Computer and the Payload Supply System are located in the electronics segment. The modifiable payload platform is the link between electronics segment and payload segment. In the payload segment are the experiments and also satellite bus components (star sensors, magnetic field sensors and antennas (low-gain and GPS)).

4.3. Payload

4.3.1. TET-1 Payload Segment & Experiments

As mentioned, 11 experiments are accommodated in the TET-1 satellite. The list of experiments is given below:

- three different types of next generation solar cells including thin-layer technology
- Lithium Polymer Battery
- two GPS receiver systems
- sensor bus system
- pico satellite propulsion system
- infrared camera as follow-up of the BIRD camera system
- Computer hardware
- RF communication system.

The accommodation of the experiments in the Payload Segment is shown in the following two figures. The accommodation has been driven by the various experiments needs as e.g. viewing directions, un-obstructed view angles for antennas, heat dissipation, etc.

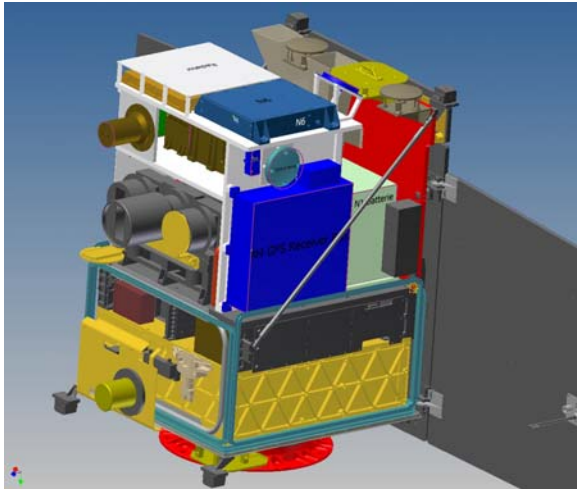

Figure 11: Accommodation of Experiments (1)

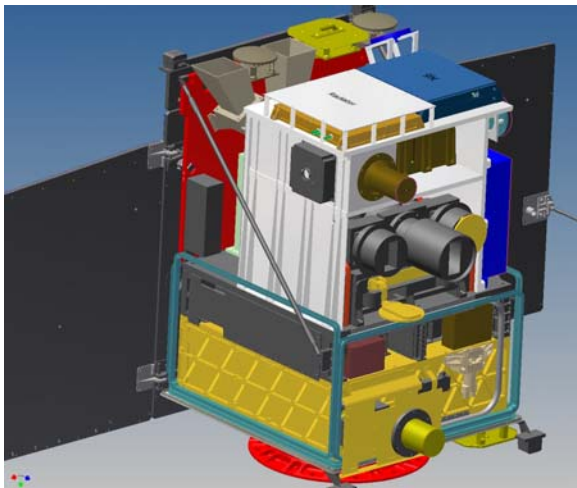

Figure 12: Accommodation of Experiments (2)

The TET-1 Payload configuration data are summarized in Table 3.

The solar cell experiments have been accommodated on the sun pointing side of TET-1 next to the Satellite Bus solar arrays, as shown in the Figure 13.

4.3.2. Payload Supply System

The interface between the Satellite Bus and the experiments is controlled via the Payload Supply System which is under Kayser-Threde responsibility. The Payload Supply System provides therefore a fixed part that interfaces to the Satellite Bus and a flexible part that can easily be adjusted to the experiments needs as sketched in Figure 14.

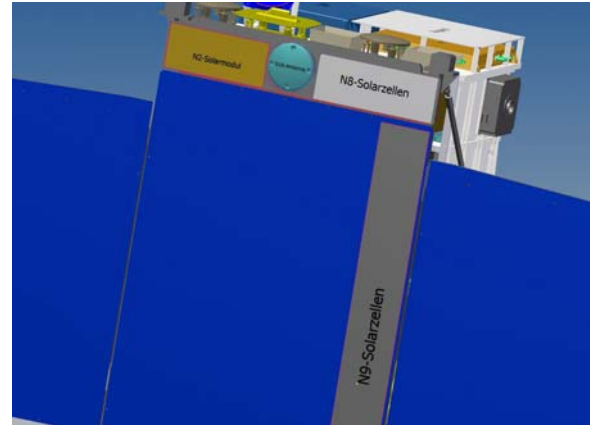

Figure 13: Accommodation of Solar cell Experiments

TET-1 Payload Data	
Dimensions:	428 mm x 460 mm x 460 mm (H x W x D)
Max. Payload Mass:	50 kg incl. mass of Payload Supply System
Power consumption cont.:	0 – 20 W incl. Payload Supply System
Power consumption max.:	160W limited in time and occurrence
Supply Voltage:	18 – 24VDC
Current max.:	8A
TM Data Rate:	2.2 Mbit/s max.
Storage:	512 MByte
Heaters:	0 to 15W

Table 3: TET-1 Payload configuration data

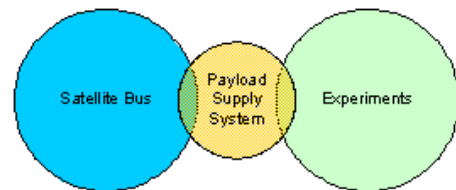

Figure 14: Payload Supply System Interface

Based on this concept the Payload Supply System can be separated into three different parts:

- the power supplies responsible for the supply of the experiments and the Payload Supply System itself
- the processor boards that are used to control all Payload Supply System activities
- the I/O boards that provide the interfaces to the experiments.

All these parts will be realized on several printed circuit boards that will be connected via a backplane. The experiments will be connected via front panel connectors.

The Payload Supply System is accommodated inside the Electronic Segment of the Satellite Bus next to the Satellite Bus Controller as shown in Figure 15.

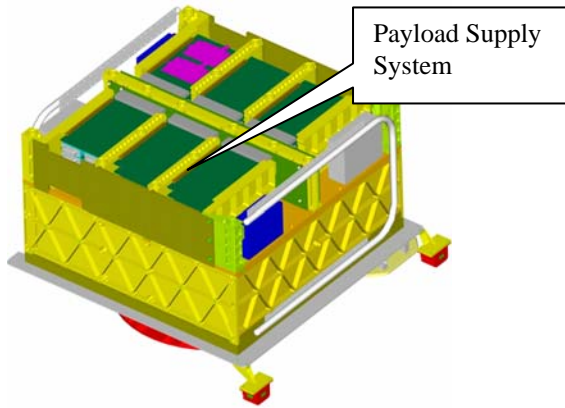

Figure 15: Accommodation of the Payload Supply System

The functions provided by the software executed on the Payload Supply System processor cover the following tasks:

- control of experiments with minimal built-in processing logic
- acquisition of housekeeping data of the experiments and the Payload Supply System itself
- acquisition of measurement data of the experiments
- temporary storage of all acquired measurement and housekeeping data
- formatting and packaging of data according CCSDS for downlink
- reception and execution of commands from the Satellite Bus Controller
- control of Payload Supply System devices as switches, circuit breakers, etc.
- management of thermal control of experiments and Payload Supply System
- boot, self-test and software update management
- Failure Detection, Isolation and Recovery, redundancy management

Via the housekeeping sensors of the Payload Supply System the software controls the heaters installed in the Payload Segment to maintain the required temperatures for operating the experiments.

The Payload Supply System decouples the single experiments from the satellite bus and ensures its full operation ability for the complete life cycle. To achieve maximum flexibility a categorization of experiments has been introduced enabling the Payload Supply System also in future TET missions to easily interface with specific experiment's needs without major changes of the Payload Supply System design concept. 4 categories have been defined which are specified as follows and shown in Figure 16:

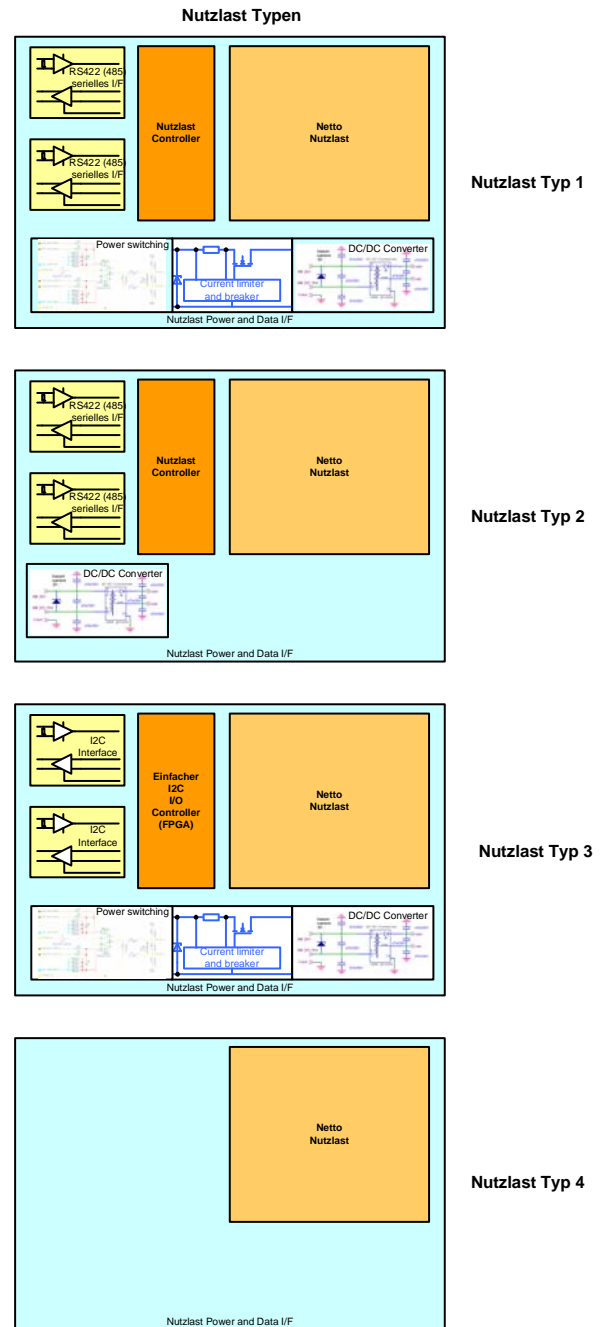

Figure 16: Categorization of experiments for the scope of modularity of the Payload Supply System

- Experiment of category 1 is an ideal full self-sustaining payload with an own payload controller with standardized serial interface and own power control unit. The only task of the Payload Supply System is to directly interface this experiment to the satellite bus.
- Experiment of category 2 differs from category 1 by taking over the power limiting and securing functionality. The decoupling from the satellite

bus is now managed by the Payload Supply System.

- Experiments of category 3 ask to be fully controlled by the Payload Supply System
- and those of category 4 brings no own infrastructure elements for payload support.

5. GROUND SEGMENT OVERVIEW

Ground Segment project management, integration, test and training as well as all LEOP activities, routine mission operation and satellite control for TET-1 will be performed at the German Space Operations Center (GSOC).

Interfaces are established to the German Remote-Sensing Data Center (DLR-internal) and to external partners such as the launch-provider (data-exchange) and to the Canadian Space Agency (CSA) as provider of additional ground-station for LEOP-support. This is done on a co-operative basis (no exchange of funds), as DLR-GSOC supports Canadian missions with its resources. DLR-owned S-Band ground stations in Weilheim, Neustrelitz and O'Higgins/Antarctica (for LEOP only) provide the necessary access to the satellite in all mission phases. This ground station concept based mainly on DLR-owned resources is one of the reasons for cost-effective project design. However, operational requirements sometimes need to be tailored to the available uplink- and downlink resources.

A so called Payload Data Center (PDC) will be provided at the location of the data reception station in Neustrelitz. The main tasks are acquisition, extraction, processing (formatting to a generic ASCII format) archiving and provision of payload data.

The 11 users with their experiments onboard TET-1 retrieve (download) their data via a secure FTP interface. The main goals for the design and implementation process of the Ground Segment can be summarized as follows:

- Minimize number of project-specific systems and tools
- Make use of multi-mission core systems (Mission Data System, Flight Dynamics, networks, etc.)
- Use of multi-mission documentation and combining documents reasonably
- Efficient pooling of multi-project resources and personnel

Figures 17 and 18 illustrate the main functions of the ground-segment and their interfaces. The core element – the so-called Mission Data System (MDS) – is already fully operational and available and just needs to be configured for TET. The only exception being the Mission Information Base (MIB) which is specific for each project as it contains the definitions of TM and TC.

Figure 20 gives an impression of the TET-1 Ground-Station Coverage and Orbit Tracks

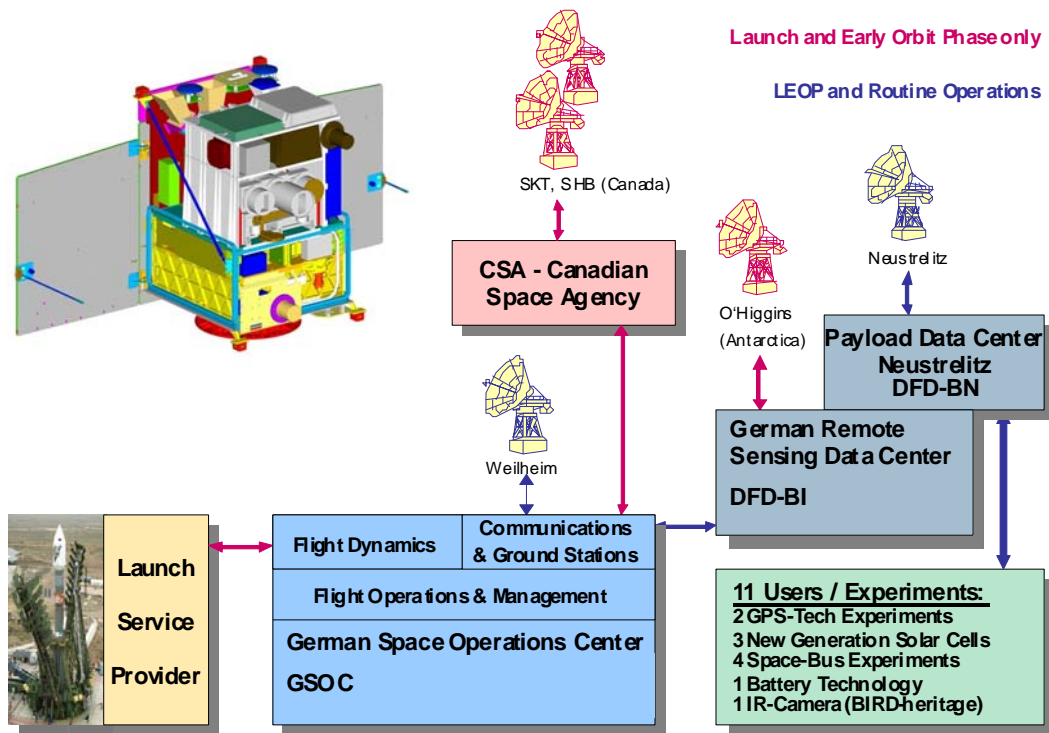

Figure 17: TET Ground Segment Overview

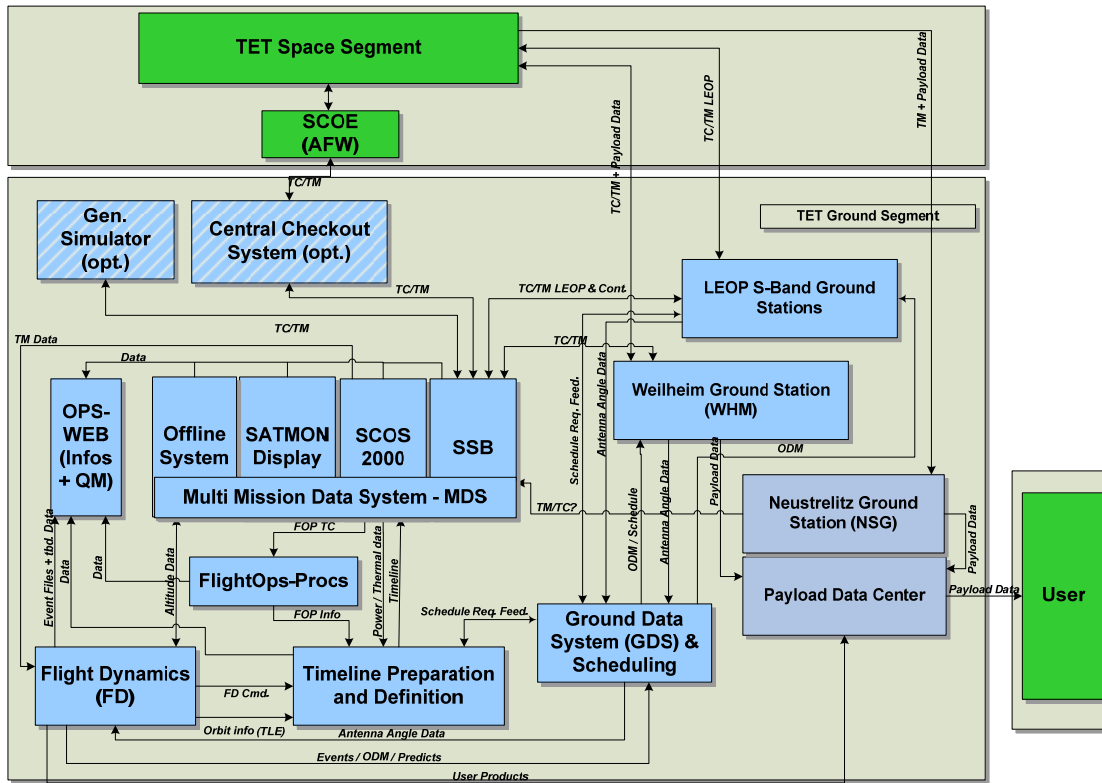

Figure 18: TET Ground Segment Functional Structure and Interfaces

LEOP:
 Saskatoon (CSA) St. Hubert (CSA)
 O'Higgins (DLR-DFD)

LEOP and Routine:
 Neustrelitz (DLR-DFD)
 Weilheim (DLR-GSOC, 2 x TM/TC)

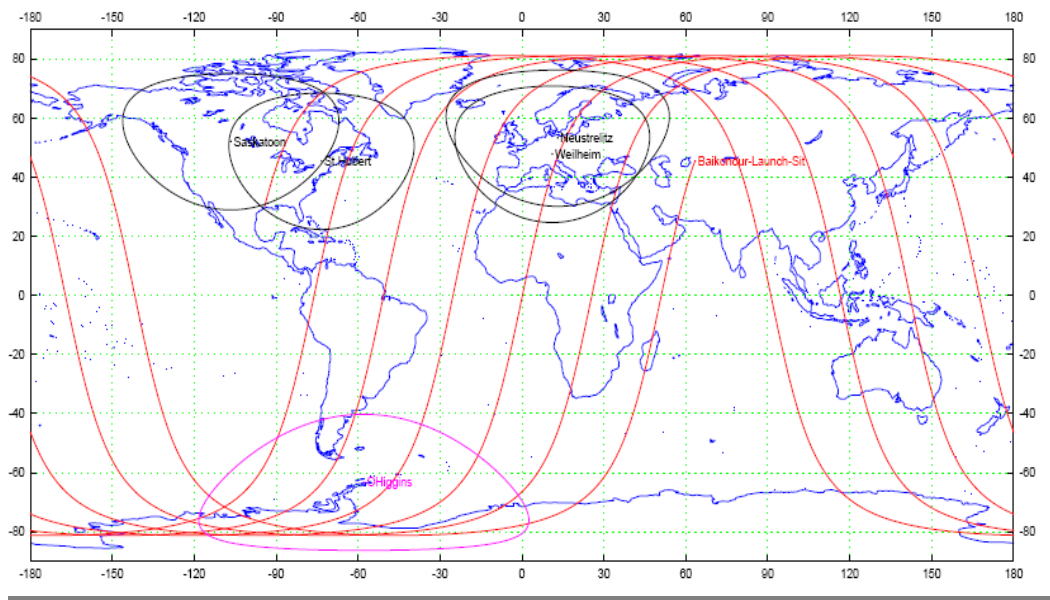

Figure 19: TET-1 Ground-Station Coverage and Orbit Tracks

6. MISSION OPERATIONS

For the TET-1 mission the ground-segment will basically provide the execution of all necessary activities for a sound operation of the space segment and a continuous survey (Monitoring & Control) of functionality and integrity of all project elements. DLR-GSOC will perform this for all mission phases after launch for both the space segment and the ground segment.

During the mission preparation phase detailed analysis and planning of the mission operation will be undertaken and the operations processes will be designed, implemented, tested and validated. In the LEOP, bus commissioning- and routine operations phase telemetry data of the satellite and payload status is received and processed and telecommands for controlled changes of the satellite are sent. Onboard power and data storage availability, S/C attitude and payload requirements for previously scheduled payload events are compiled and executed.

In preparation for this, training sessions will be performed during project phase D for all operations personnel at DLR/GSOC. The training comprises of class room and simulation sessions.

Due to the BIRD heritage, the operational ground processes are already largely known to the experienced operations personnel at the control centre GSOC and at the PDC in Neustrelitz. After launch and successful orbit injection and separation of TET from the launcher, GSOC is responsible for execution of early orbit operations. The above figure illustrates the first orbits after launch and the related coverage zones by the available ground-stations. LEOP is characterized as follows:

- Launch from Baikonour with Soyuz as secondary payload ("piggy-back")
- Separation from Fregat upper-stage after injection in desired orbital altitude. The final separation location is still to be defined
- Spacecraft initiates automatic activation sequence and transits to safe-mode (attitude, power, thermal, communication)
- Initial acquisition of signal over DLRs O'Higgins (Antarctica) or Weilheim (Germany) GS
- Begin of orbit determination process utilizing tracking data gained from the ground-station in Weilheim respectively from the external LEOP support stations
- Start of checkout and ground-commanded configuration activities
- Support by 2 Canadian ground-stations begins after 4 orbits
- LEOP and bus commissioning duration: 7 days followed by activation of payloads and their checkout.

The routine mission operation and satellite control will be performed by GSOC engineering personnel during normal working hours with the support of a multi mission flight operations team (MMFS-team) responsible for shift operations as required. Three different pre-defined operational scenarios are identified to the present:

- General activities on a weekly basis,
- Additional activities during 4 days once per month,
- Specific activities during 2 days at start and end of mission.

Routine operation is characterized as follows:

- Ops-planning, health-monitoring and onboard maintenance at GSOC
- Upload of time-tagged executable commands to bus and payload: 3 days in advance, weekly cycle
- Commanding and TM reception: once per day via Weilheim ground-station
- Upload of S/W and maintenance on request
- Download of data (payload & bus): 4 times a day
- Data reception and processing at Payload Data Center: automatic, 7 days a week

Operational tasks and responsibilities within the ground-segment during mission conduct:

- The DLR ground station in Weilheim will serve as main uplink (TC) and housekeeping telemetry reception (HK-TM) station.
- The DLR ground station in Neustrelitz will be used as main downlink station for payload data
- S-band data will be routed in real time from Weilheim and Neustrelitz to the Operations Center in Oberpfaffenhofen (GSOC) and all raw data will be stored at the receiving ground-stations for a limited period.
- Calibrated housekeeping data (i.e. uplink and downlink) will be archived at DLR/GSOC and can be used at GSOC for offline analysis, while payload data will be formatted to an additional generic ASCII format, provided and archived at Neustrelitz together with the raw instrument source packets and other auxiliary data products
- Mission control, preparation and execution of flight-operations, health-monitoring and performance analysis is performed at GSOC, as well as permanent orbit determination utilising GPS data and 'station predicts' will be generated to support acquisition of the satellite by the ground-stations.

The above outlined operations concept for TET based on DLR internal resources and on the multi-mission approach will make the most efficient use of the existing facilities, processes and teams as TET will be another mission added to the pool of presently 5 satellites permanently operated at GSOC.

7. SERVICES AND PRODUCTS

All users with experiments onboard TET-1 will be provided two payload data sets with different formats on a ftp-server. The Payload Data Centre (PDC) processes the received payload data during and immediately after data reception, which is planned four times a day.

Data Products	Content	Type	Availability	Remark
Auxiliary Data	- Ops-planning and as flown	tbd	Not restricted	
	- Orbit	tbd	Not restricted	
	- Attitude	tbd	Not restricted	
	- Bus-HK-data (including NVS)	ASCII	Not restricted	
	- Logs	ASCII	Not restricted	various
Payload Data	Raw Instrument Source Packets (ISP)	Binary	User Specific (pass-word protected access)	Generic format, but specific content for each user
	Converted File	ASCII	User Specific (pass-word protected access)	One generic format for all users, contents specific.

Table 4 TET Ground-Segment Data Products

The products (instrument source packets in raw binary form and as ASCII text file) will be made available at the ftp server 15 min after finishing data reception, secured by protected and selective access. The format of both payload data products for all 11 users is identical, while contents differ, of course. The user additionally receives all auxiliary data (required for calibration purposes or additional processing) provided by GSOC via the same interface. All data are stored on a permanent archive and a function for later retrieval is provided.

8. SUMMARY & OUTLOOK

The TET-1 mission is a national program funded by the German Space Agency. The TET program started with Phase A in January 2005, which ended October 2006. The TET-1 Phase B started in June 2007, followed by a successful SRR in August 2007 and was completed after the PDR beginning 2008. Meanwhile Kayser-Threde is also selected as Prime Contractor for the Phase C/D. The Kick-off has been performed in July 2008 and the launch date is scheduled for mid 2010, not only the satellite has to be ready within two years but also the ground segment and the launch segment.

The goal of TET is the support of German industry and research institutes with the on-orbit verification of new and innovative satellite technologies. For this purpose regular and reliable flight opportunities shall be offered, which can be realized on short notice. TET shall provide the required verification platform and

shall be based on a satellite bus which was qualified on orbit during the BIRD mission.

In total, eleven different payloads were selected to be demonstrated on TET-1. These include optical experiments such as an infrared camera as well as novel solar cells, batteries, on-board computers, GPS receivers and a propulsion system.

Finally, TET with its new standardized bus and modular payload supply system shall serve also in future as standardized platform for on-orbit-verification purposes. The payload compartment is large enough to accommodate even complex experiments, and the bus performance is powerful enough to provide also challenging mission requirements as will be demonstrated for the IR-payload onboard TET-1.

With the TET concept Kayser-Threde is able to enlarge its possibilities to offer flight opportunities for in-orbit demonstration which are based up to now only on the KAP concept for short missions. KAP offers the feature of access to space with the experiments staying attached to launcher upper stages using remaining launcher payload capabilities and upper stage performances. The KAP concept has been developed for Ariane 5 and VEGA as well as recently for SOYUZ/FREGAT [2]. A demo-mission is planned parallel to the TET-1 mission in 2010.

Based on the two concepts TET and KAP Kayser-Threde defines its role meanwhile as flight opportunity broker and invites experimenters to directly contact Kayser-Threde to assess possibilities for access to space for technology and/or scientific experiments' in-orbit demonstration with various mission durations.

9. ACKNOWLEDGEMENT

The Phase B activities for TET-1 have been funded by DLR Space Agency under contract no. 50 RV 0701.

The Phase C/D activities are funded by DLR Space Agency under contract no. 50 RV 0801.

10. REFERENCES

- [1] E. Lorenz, H. Jahn: BIRD: more than 3 years experience in orbit; Small satellites for Earth Observation, Selected Proceedings of the 5th International symposium of the International Academy of Astronomics, 102-109 (2005)
- [2] C. Kaiser, H. Pfeuffer, G. Pont, A. Smirnow, S. Ishin: The Carrier KAP@FREGAT for Technology In-Orbit Demonstration and Low-Gravity Research using the FREGAT Upper Stage, Proceedings of the 59th IAF Congress, 29.09. – 3.10.2008, Glasgow, Scotland, UK, Paper No. IAC-08.A2.5.9